

(8+322) km  
Pralaida

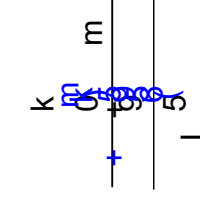

Valčiūnų st.  
13+374 (13+377) km

Kirtimų st.  
5+359 (5+364) km

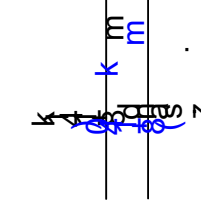
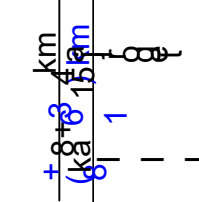
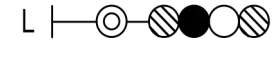
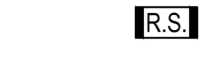

8+154 km pervaža  
(8+163) km  
Vmaks. = 80 km/h

8+154 km pervaža  
(8+163) km  
Vmaks. = 80 km/h

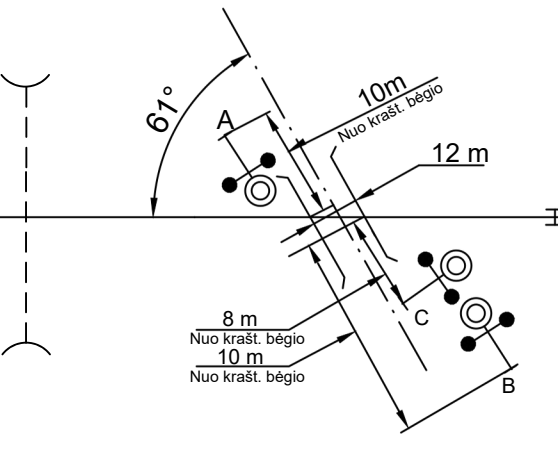

7 R.S.2 R.S.1  
A.S.

L p. = 22 m  
V max. = 80 km/h  
L skaič. = 821 m  
T praneš. = 37 s  
  
L fakt. lyg. = 1981 m    L fakt. nelyg. = 1558 m  
T fakt. lyg. = 89 s    T fakt. lyg. = 70 s  
T delsl. lyg. = 52 s    T delsl. nelyg. = 33 s

1. Tarpstotyje įrengta vienkelė dvipusė 25 HZ kintamosios srovės kodinė tarpstočio automatinė kelio blokuotė.
2. Tipinis albumas - AB-1-K-25-AT-80.
3. Bėgių grandinių normalė RC25-AT-P-83.